

INSPECTION

1. INSPECT SPEEDOMETER ON-VEHICLE

Using a speedometer tester, inspect the speedometer for allowable indication error and check the operation of the odometer.

HINT:

Tire wear and tire over or under inflation will increase the indication error.

USA (mph)	
Standard indication	Allowable range
20	19 – 22
40	39 – 42.5
60	59.5 – 63.5
80	80 – 85
100	100 – 105.5
120	120 – 125.5
140	140 – 146

If error is excessive, replace the combination meter.

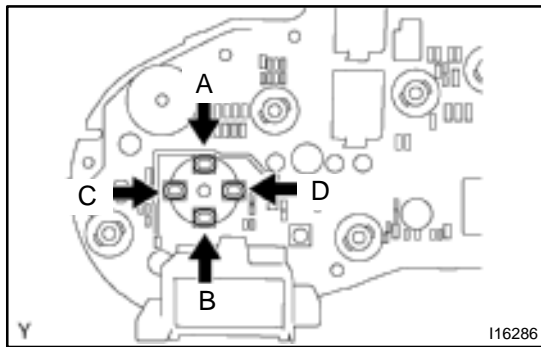

2. INSPECT SPEEDOMETER RESISTANCE

Measure the resistance between terminals with an ohmmeter at the positions shown in the illustration.

Tester connection	Resistance (Ω)
A – B	250
C – D	250

If resistance value is not as specified, replace the combination meter.

3. INSPECT TACHOMETER ON-VEHICLE

(a) Connect a tune-up test tachometer, and start the engine.

NOTICE:

Reversing the connection of the tachometer will damage the transistors and diodes inside.

(b) Compare the tester indications with tachometer indications.

RPM (DC 13.5 V, 25° C (77° F))

Standard indication	Allowable range
700	630 – 770
1,000	900 – 1,100
2,000	1,850 – 2,150
3,000	2,800 – 3,200
4,000	3,800 – 4,200
5,000	4,800 – 5,200
6,000	5,800 – 6,200
7,000	6,800 – 7,200

If error is excessive, replace the combination meter.

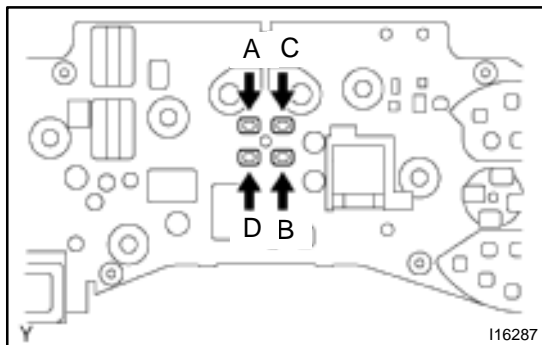

4. INSPECT TACHOMETER RESISTANCE

Measure the resistance between terminals with an ohmmeter at the positions shown in the illustration.

Tester connection	Resistance (Ω)
A - B	250
C - D	250

If resistance value is not as specified, replace the combination meter.

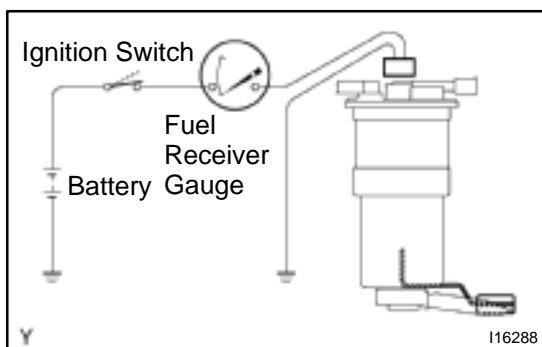

5. INSPECT FUEL RECEIVER GAUGE OPERATION

- Disconnect the connector from the fuel pump assembly.
- Turn the ignition switch ON, check that the receiver gauge needle indicates EMPTY.

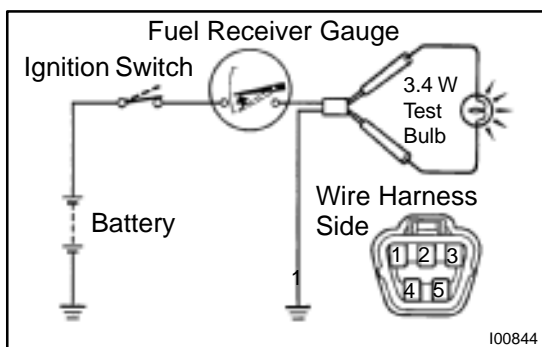

- Connect terminals 2 and 3 of the wire harness side connector through a 3.4 W test bulb.
- Turn the ignition switch ON, check that the bulb lights up and receiver gauge needle indicators EMPTY.

If operation is not as specified, inspect the sender gauge resistance.

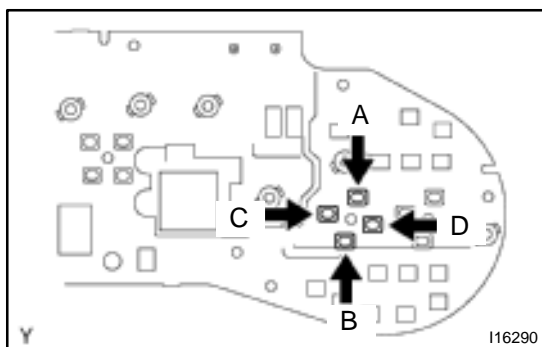

6. INSPECT FUEL RECEIVER GAUGE RESISTANCE

Measure the resistance between terminals with an ohmmeter at the positions shown in the illustration.

Tester connection	Resistance (Ω)
A - B	250
C - D	250

If resistance value is not as specified, replace the combination meter.

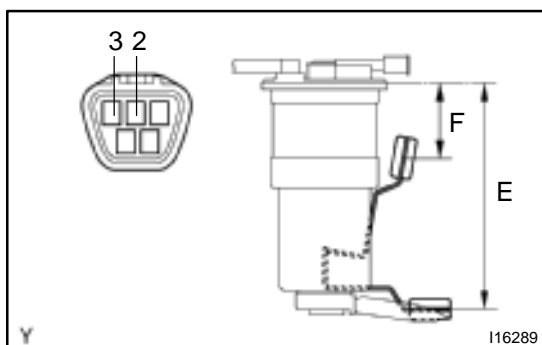

7. INSPECT FUEL SENDER GAUGE RESISTANCE

Measure the resistance between terminals 2 and 3 for each float position.

Float position: mm (in.)	Resistance (Ω)
F: Approx. 68.8 (2.71)	Approx. 16.4
E: Approx. 207.4 (8.17)	Approx. 192.7

If resistance value is not as specified, replace the sender gauge.

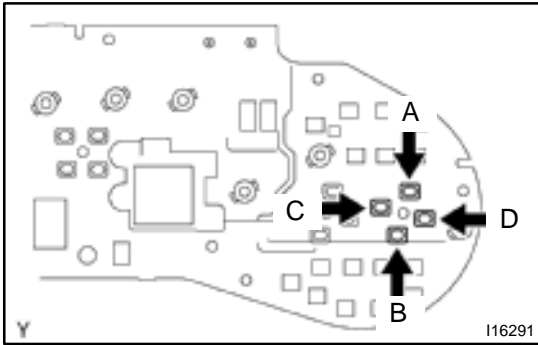

8. INSPECT ENGINE COOLANT TEMPERATURE RECEIVER GAUGE RESISTANCE

Measure the resistance between terminals with fixing pointer to the stopper.

Tester connection	Resistance (Ω)
A - B	250
C - D	250

If resistance value is not as specified, replace the combination meter.

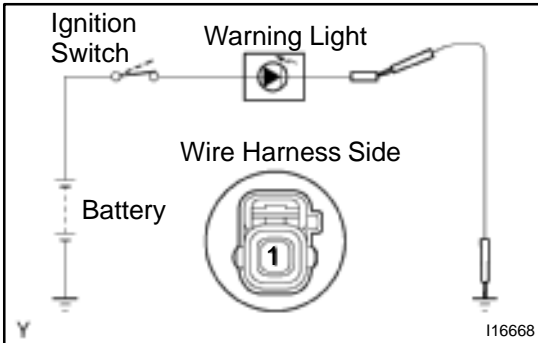

9. INSPECT LOW OIL PRESSURE WARNING LIGHT

- Disconnect the connector from the warning switch and ground terminal of the wire harness side connector.
- Turn the ignition switch ON, check that the warning light lights up.

If the warning light does not light up, test the LED or inspect wire harness.

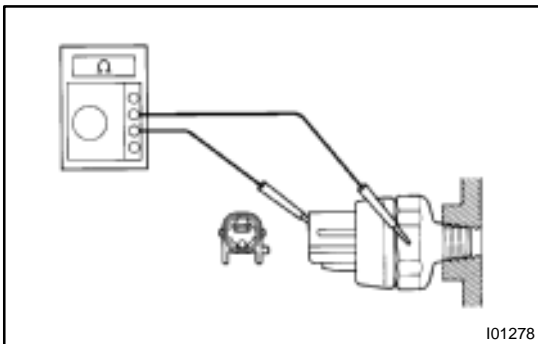

10. INSPECT LOW OIL PRESSURE SWITCH CONTINUITY

- Check that continuity exists between terminal and ground with the engine stopped.
- Check that no continuity exists between terminal and ground with the engine running.

HINT:

The oil pressure should be over 24.5 kPa (0.25 kgf/cm², 3.55 psi).

If operation is not as specified, replace the switch.

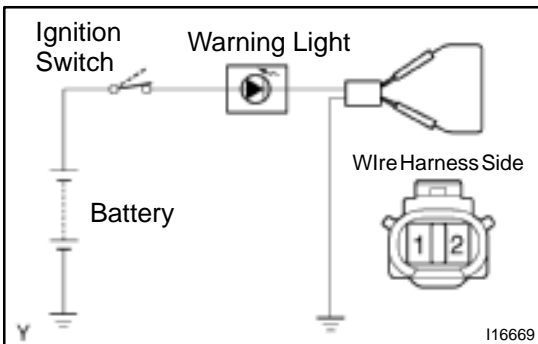

11. INSPECT BRAKE WARNING SYSTEM LIGHT

- Disconnect the connector from the brake fluid warning switch.
- Connect terminals of the wire harness side of the level warning switch connector.
- Start the engine, check that the warning light lights up.

If the warning light does not light up, test the LED or wire harness.

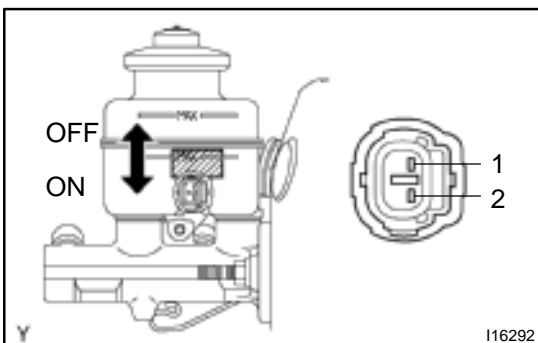

12. INSPECT BRAKE FLUID LEVEL WARNING SWITCH CONTINUITY

- Remove the reservoir cap and strainer.
- Disconnect the connector.
- Check that no continuity exists between terminals with the switch OFF (float up).
- Use syphon, etc. to take fluid out of the reservoir.
- Check that continuity exists between terminals with the switch ON (float down).

- (f) Pour the fluid back in the reservoir.
- If operation is not as specified, replace the switch.

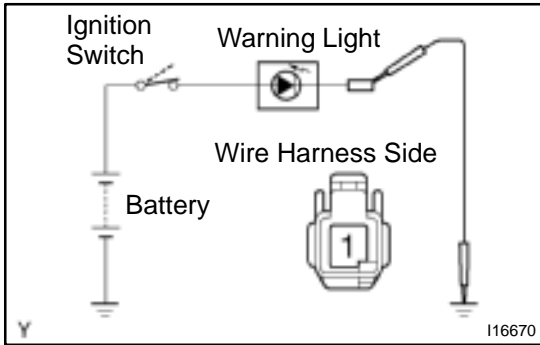

13. INSPECT PARKING BRAKE WARNING LIGHT

- (a) Disconnect the connector from the parking brake switch.
 - (b) Ground terminal of the wire harness side connector.
 - (c) Start the engine, check that the warning light lights up.
- If the warning light does not light up, test the LED or inspect wire harness.

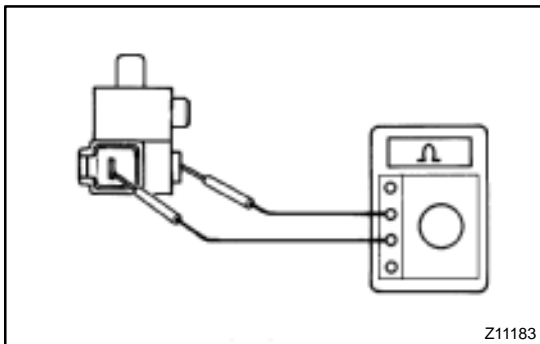

14. INSPECT PARKING BRAKE SWITCH CONTINUITY

- (a) Check that continuity exists between terminal and switch body with the switch ON (switch pin released).
 - (b) Check that no continuity exists between terminal and switch body with the switch OFF (switch pin pushed in).
- If operation is not as specified, replace the switch or inspect ground point.

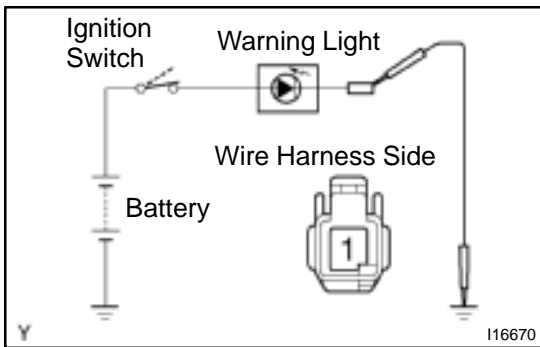

15. INSPECT OPEN DOOR WARNING LIGHT

- (a) Disconnect the connector from the door courtesy switch.
 - (b) Ground terminal of the wire harness side connector.
 - (c) Start the engine, check that the warning light lights up.
- If the warning light does not light up, test the LED or inspect wire harness.

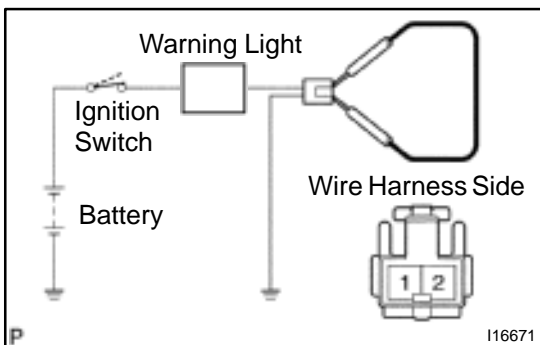

**16. Driver's side:
INSPECT SEAT BELT WARNING LIGHT**

- (a) Disconnect the connector from buckle switch and ground terminal on the wire harness side connector.
 - (b) Turn the ignition switch ON and check that the warning light lights up.
- If the warning light does not light up, test the LED or inspect wire harness.

**17. Driver's side:
INSPECT BUCKLE SWITCH CONTINUITY (See page BE-46)**

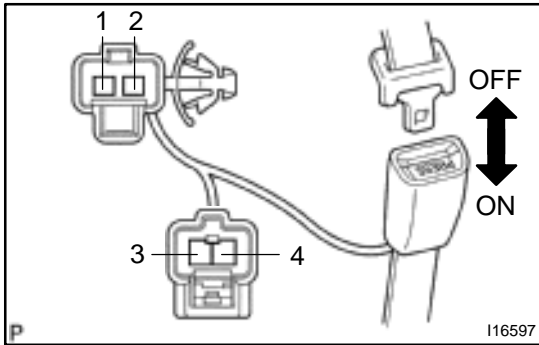

- 18. Passenger's side:
INSPECT BUCKLE SWITCH CONTINUITY**
- (a) Check that continuity exists between terminals 1 and 3 the switch side connectors with the switch OFF (belt fastened).
 - (b) Check that no continuity exists between terminals 1 and 3 the switch side connectors with the switch ON (belt unfastened).

If operation is not as specified, replace the switch.

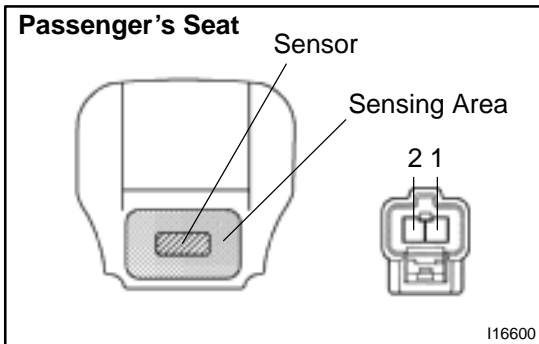

**19. Passenger's seat only:
INSPECT SEAT BELT WARNING OCCUPANT DETECTION SENSOR CONTINUITY**

Check that continuity exists between terminals 1 and 2 when pressing the sensing part.
If operation is not as specified, replace the seat cushion pad with sensor.

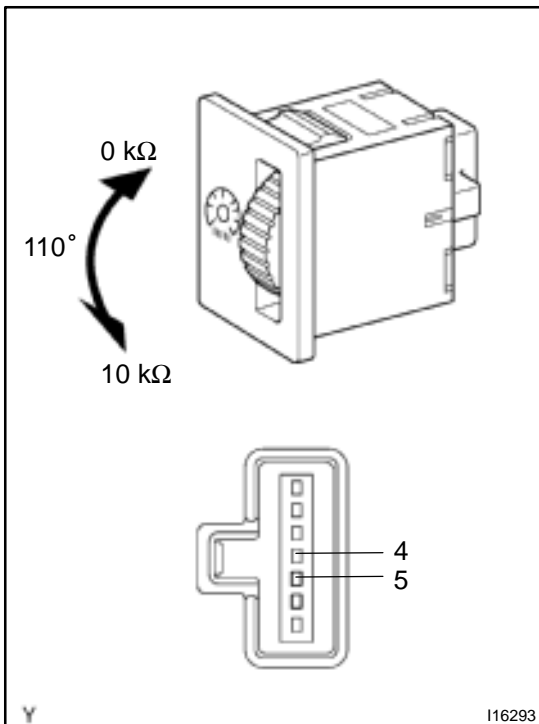

20. INSPECT LIGHT CONTROL RHEOSTAT OPERATION

Gradually, turn the rheostat knob from the bright side to the dark side and check that the resistance decreases from 10 kΩ to 0 Ω between terminals 4 and 5. (Rheostat knob turned to clockwise)
If operation is not as specified, replace the light control rheostat.